

INTRODUCTION

CRISPR/Cas system

This system has been found in the genomes of most Archaea and Bacteria, playing an important role in their immunity against phages and invading plasmids

Clustered Regularly Interspaced Short Palindromic Repeats

To date, there are several CRISPR systems characterized, and among them, the *Streptococcus pyogenes* type II system has been the most explored.

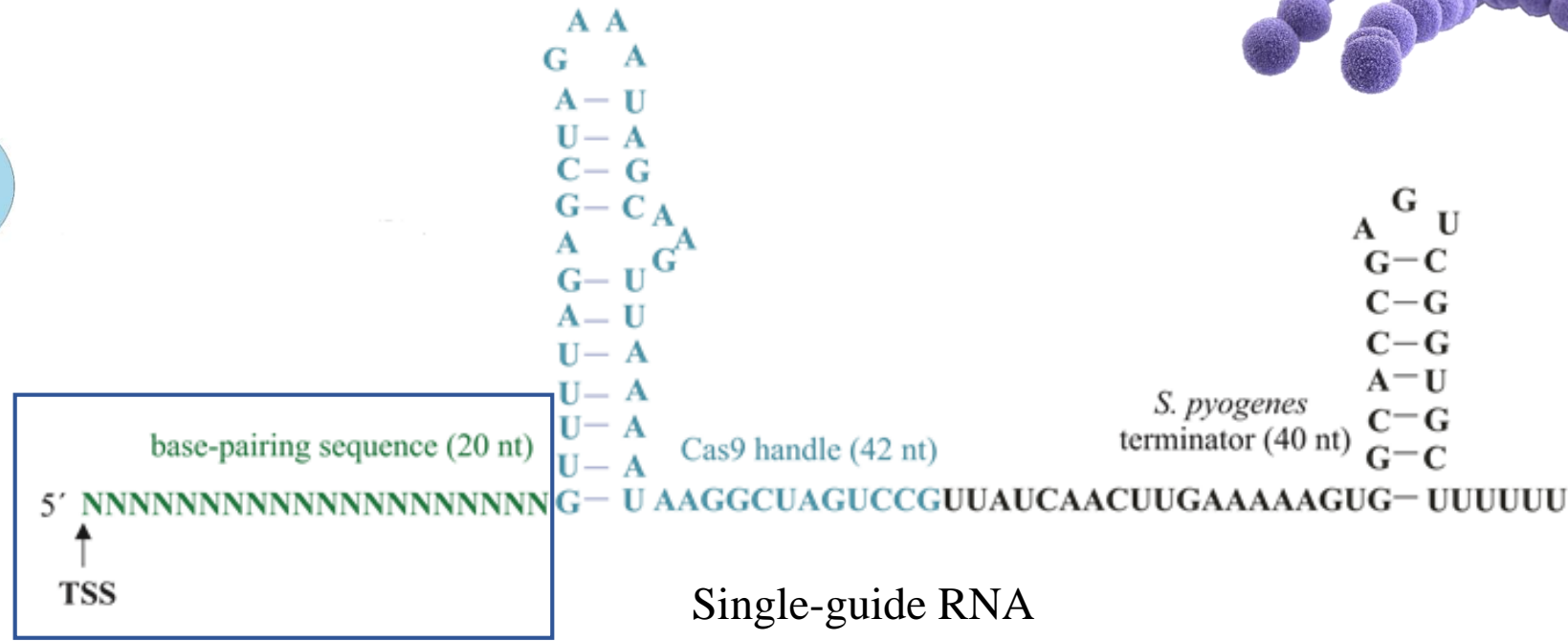
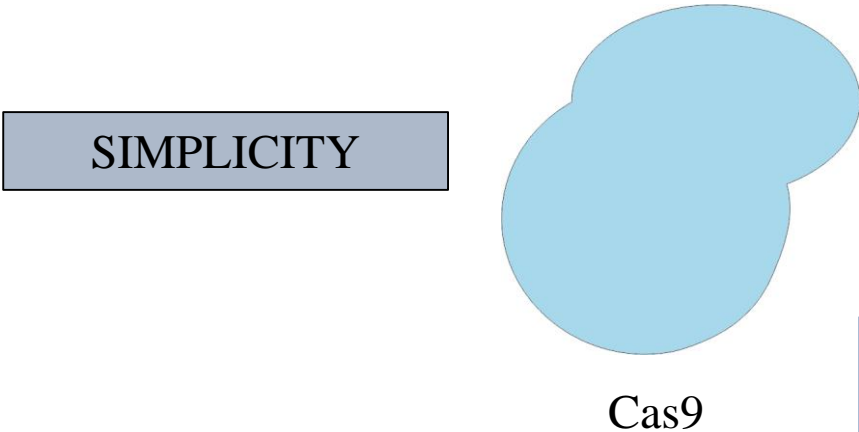

INTRODUCTION

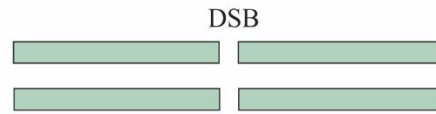
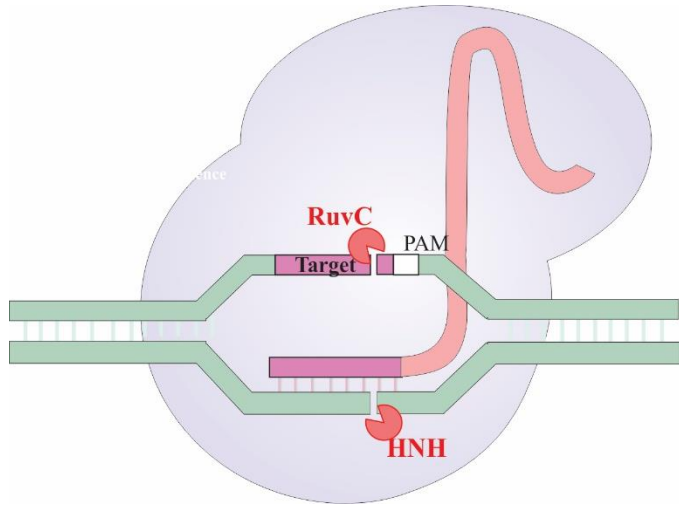

Double-strand breaks are often **lethal** in prokaryotes

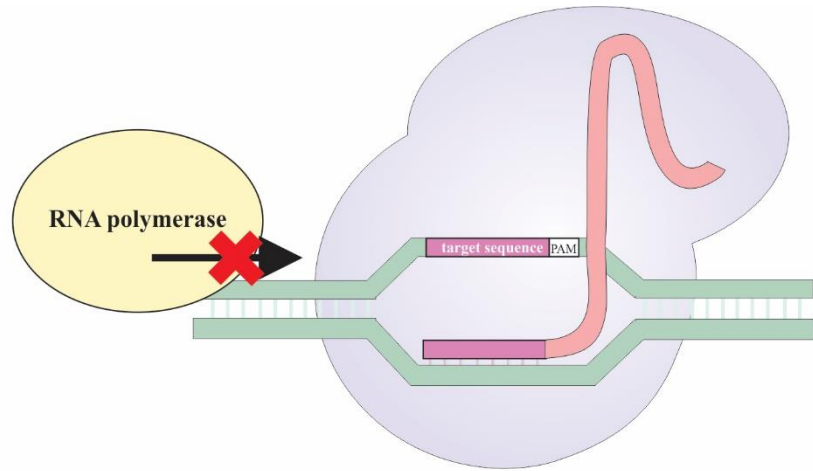

A catalytically dead Cas9 (dCas9) is an alternative to obtain gene silencing rather than disruption

CRISPR interference (CRISPRi)

METHODS



METHODS

5' ATG... CCTTCGGTATCTTTTCGGATGGT... TAA 3' Coding strand
3' TAC... GGAAGCCATAGAAAAGCCTACCA... ATT 5' Template strand
PAM Protospacer

Single-guide RNA cassette

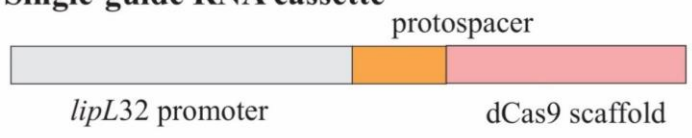

sgRNA cassette

METHODS

5' ATG... CCTTCGGTATCTTTTCGGATGGT... TAA 3' Coding strand
3' TAC... GGAAGCCATAGAAAAGCCTACCA... ATT 5' Template strand
PAM Protospacer

Single-guide RNA cassette

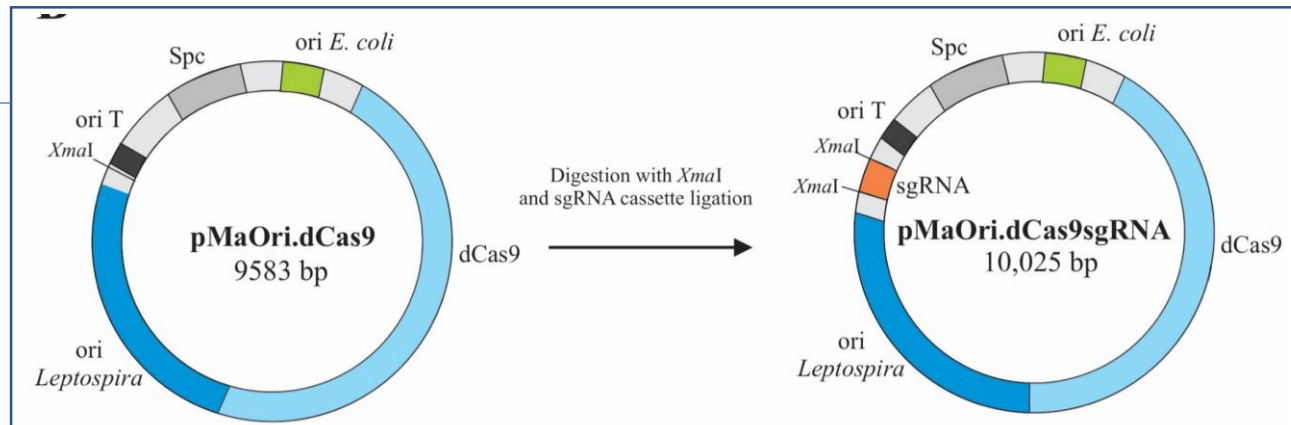
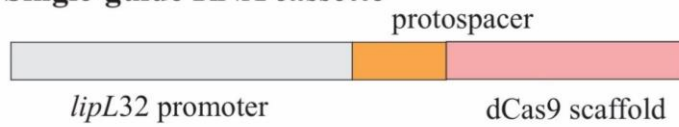

Plasmid construction

METHODS

5' ATG... CCTTCGGTATCTTTTCGGATGGT... TAA 3' Coding strand
3' TAC... GGAAGCCATAGAAAAGCCTACCA... ATT 5' Template strand
PAM Protospacer

Single-guide RNA cassette

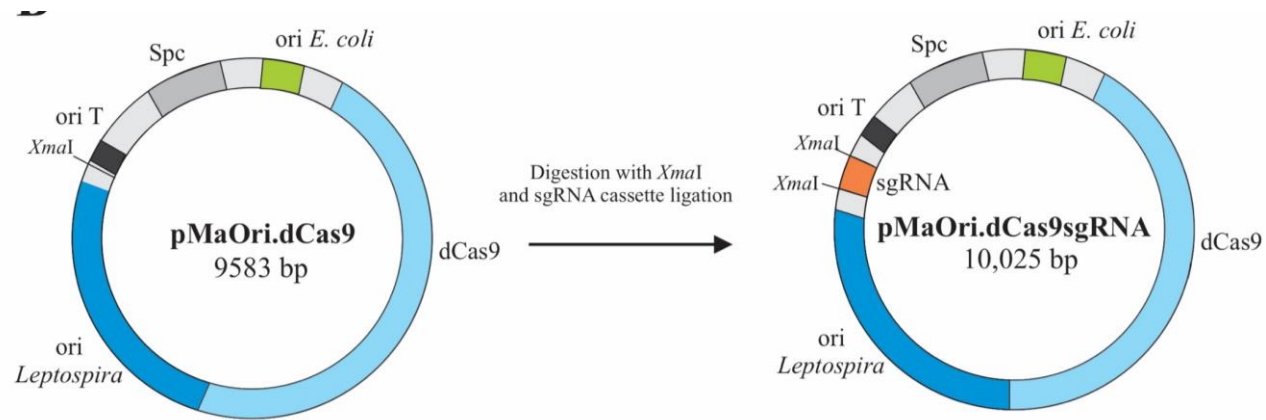
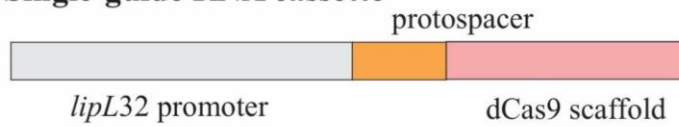

Leptospira spp. transformation by conjugation

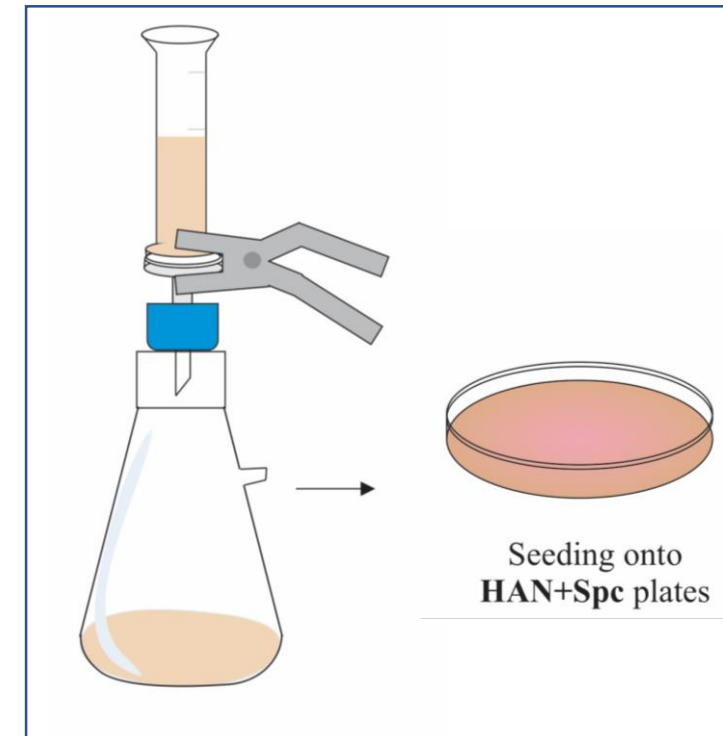

RESULTS

Proof of concept: silencing of the highly transcribed *lipL32* gene

The application of CRISPRi to *L. interrogans* resulted in a **complete silencing** of the major LipL32 protein

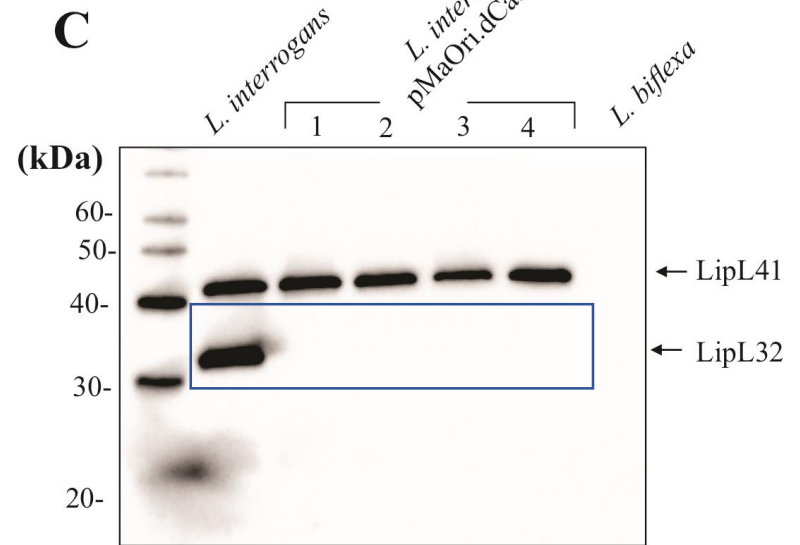
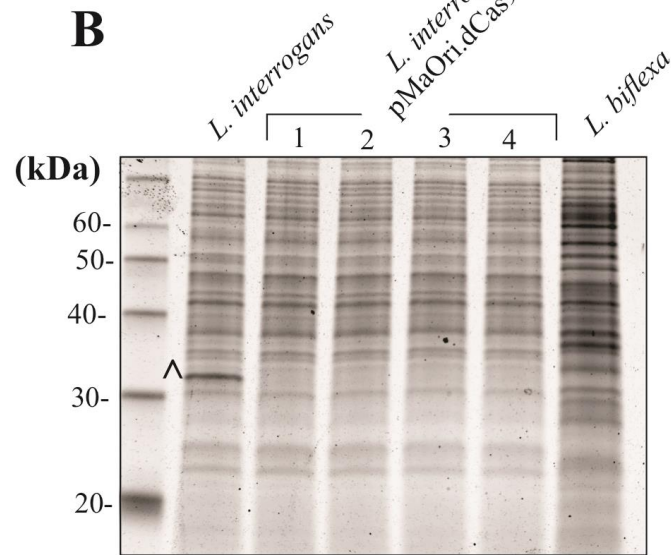
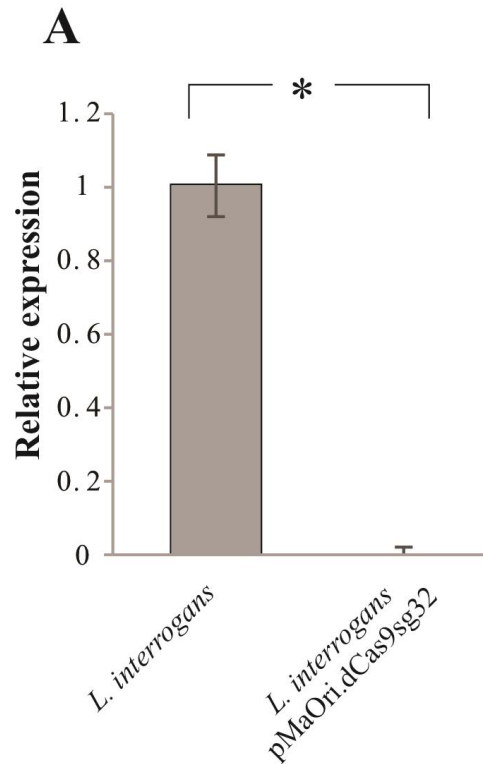
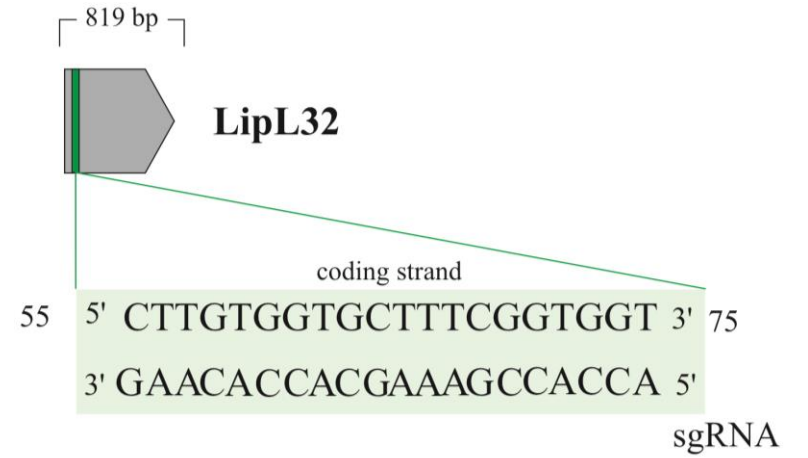

RESULTS

Stability of gene silencing

Even though CRISPRi tool is episomal, stable silencing could be observed until passage 3 in HAN media with no antibiotic

Growth in the presence of spectinomycin could completely restore silencing.

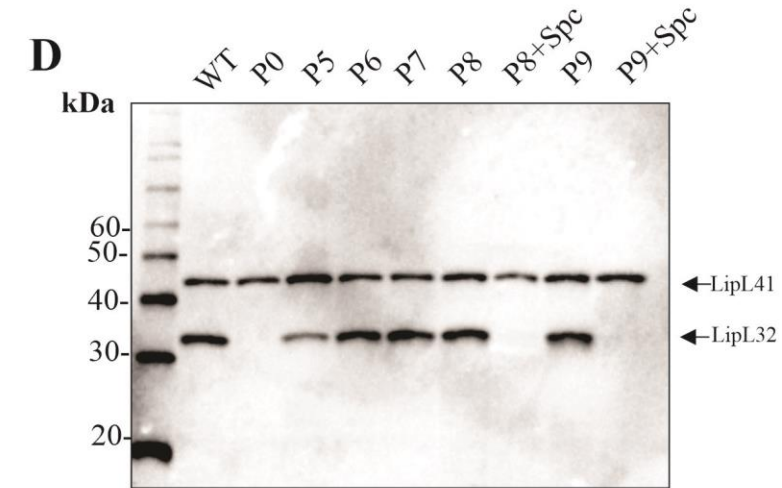
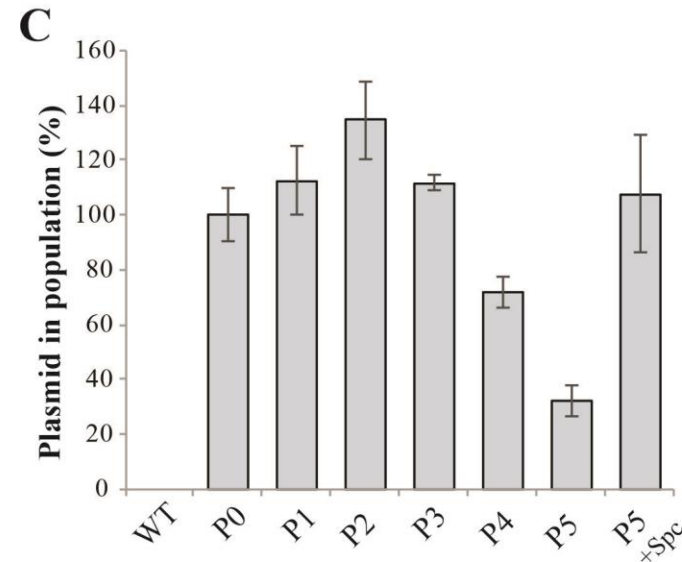
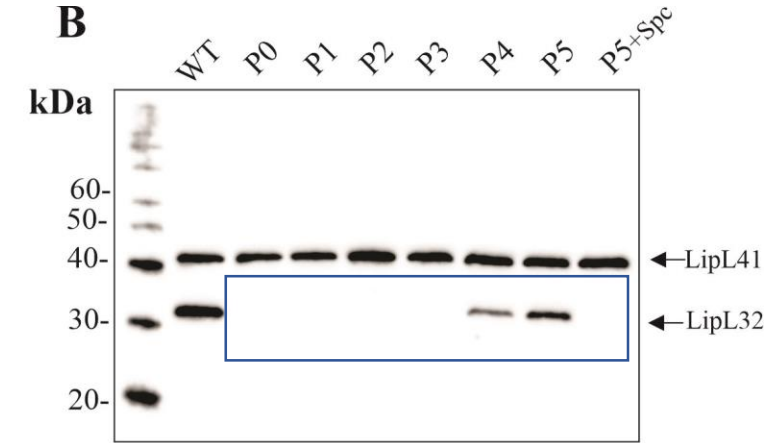
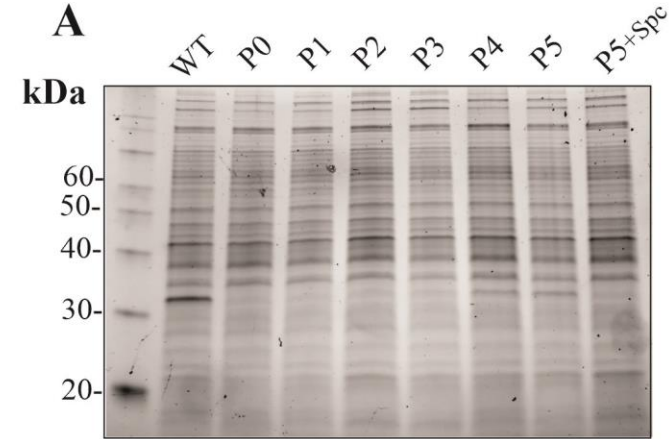

RESULTS

In vitro studies have demonstrated the ability of LigA and LigB protein to interact with host complement molecules

These proteins display overlapping properties and could be responsible for serum resistance displayed by pathogenic *Leptospira* strains.

Conserved N-terminal region

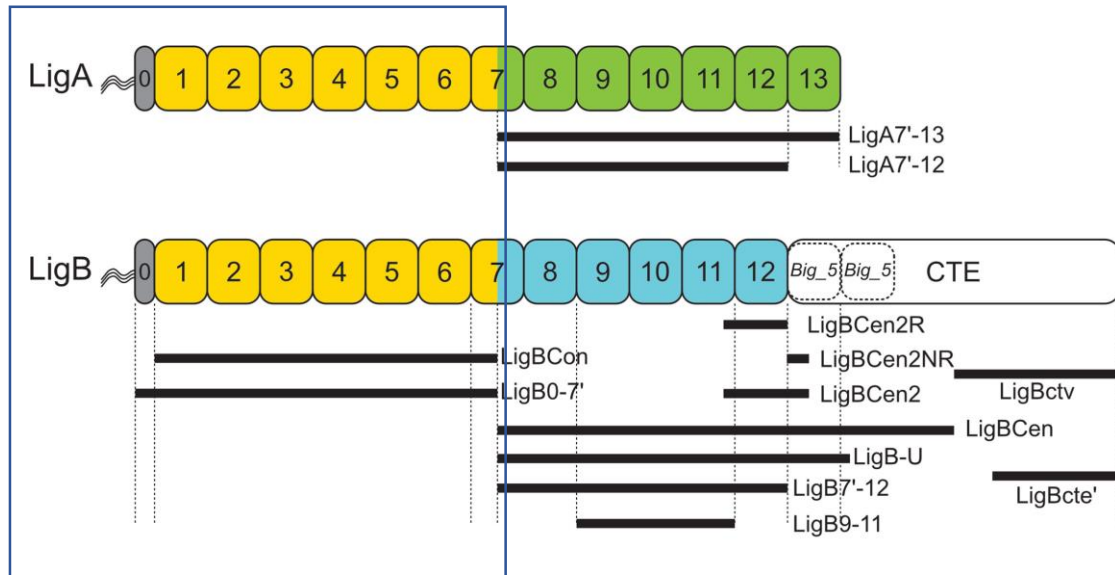

Haake and Matsunaga (2021)

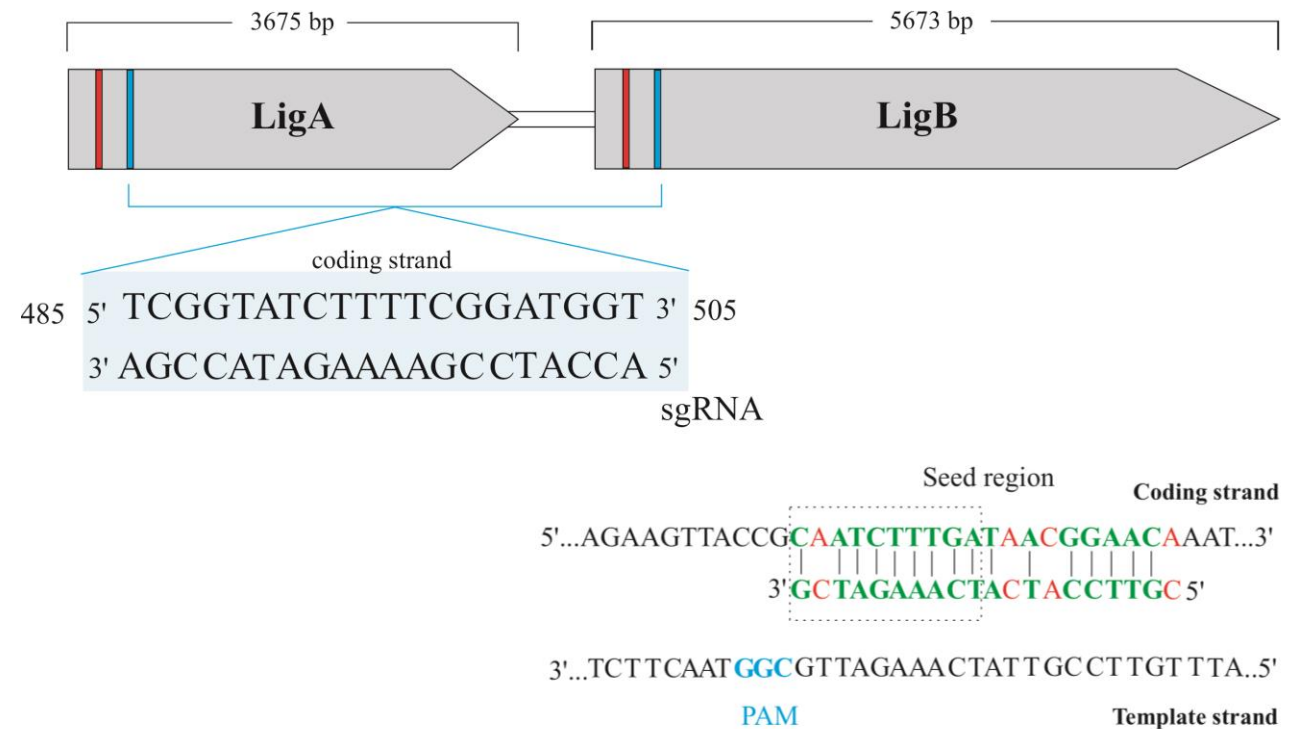

RESULTS

Concomitant silencing of LigA and LigB and effect upon serum resistance

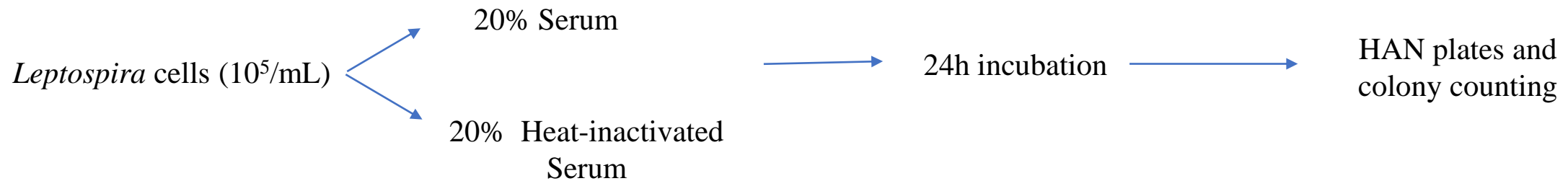
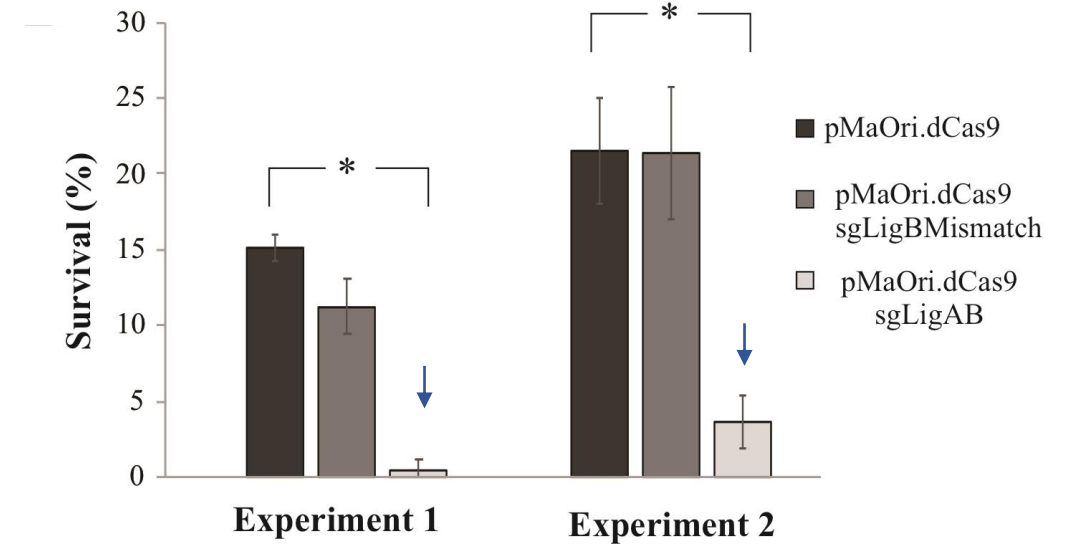
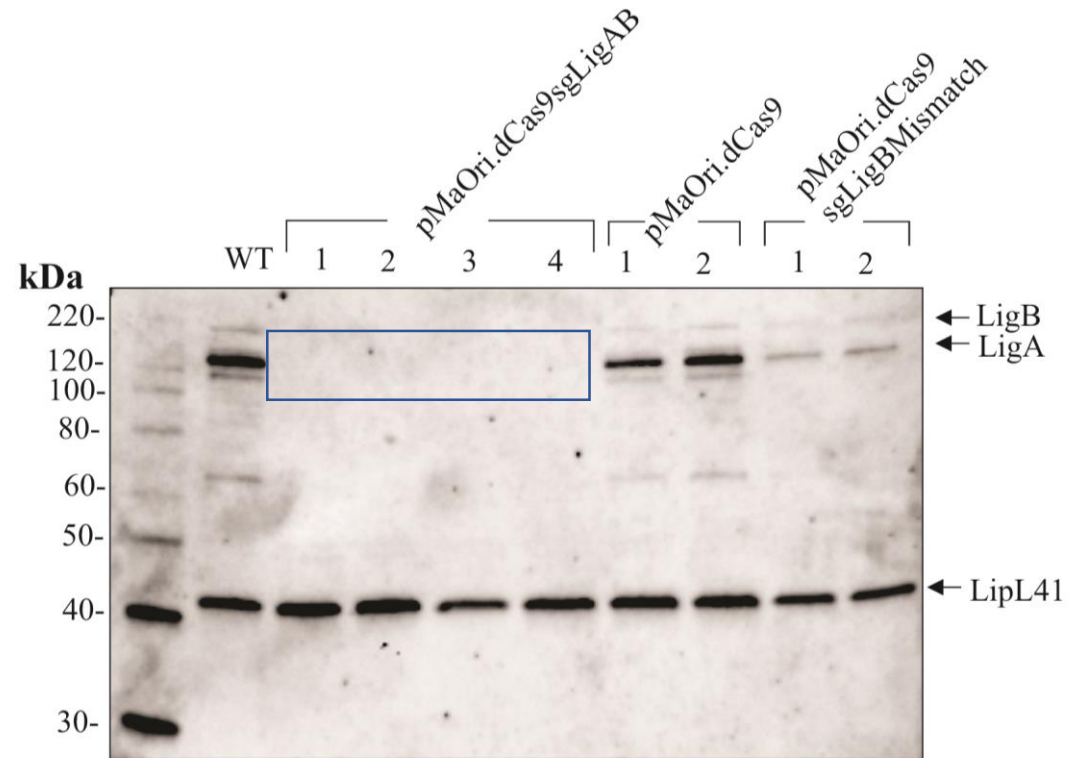

RESULTS

Virulence assays in Hamster model of infection

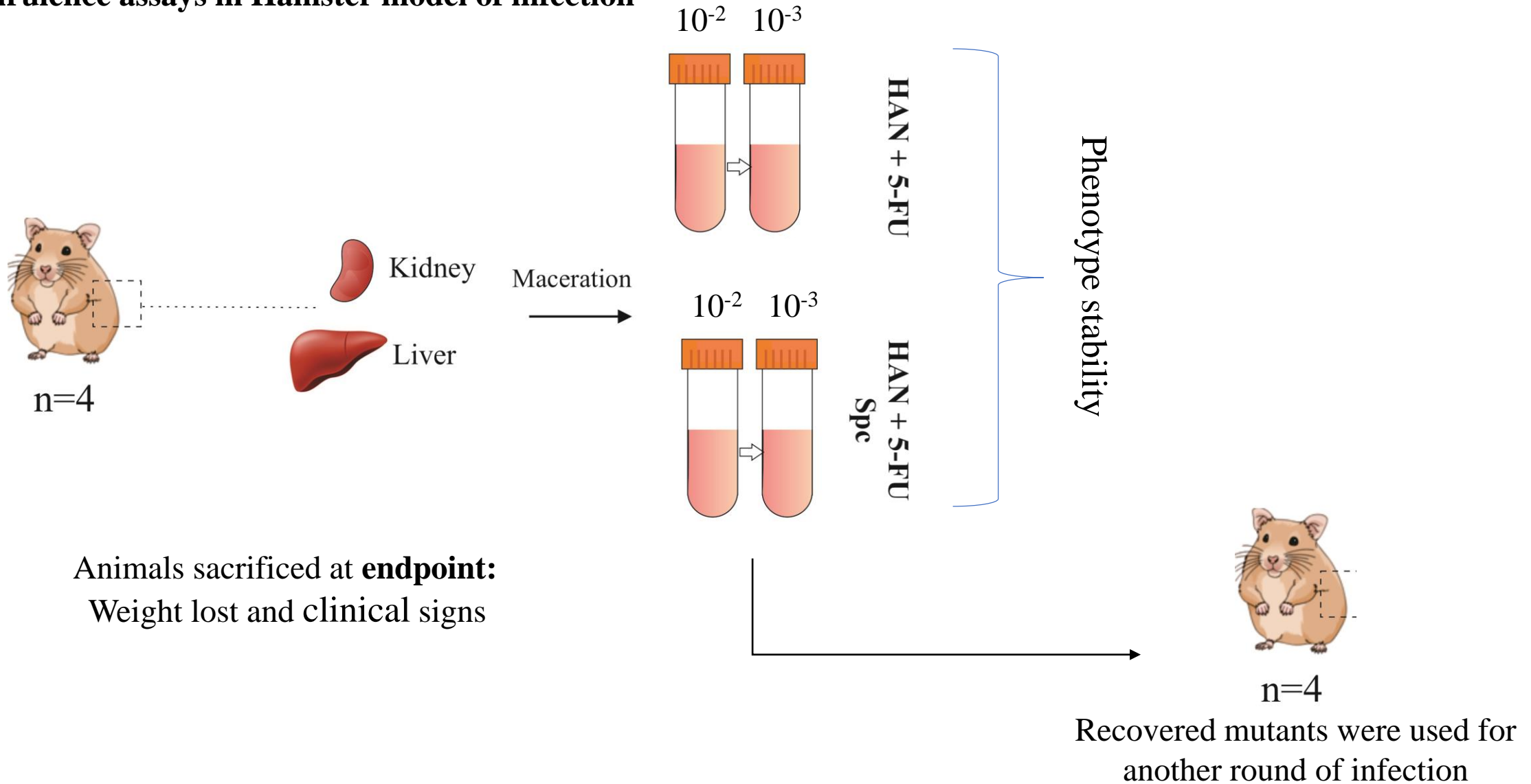

RESULTS

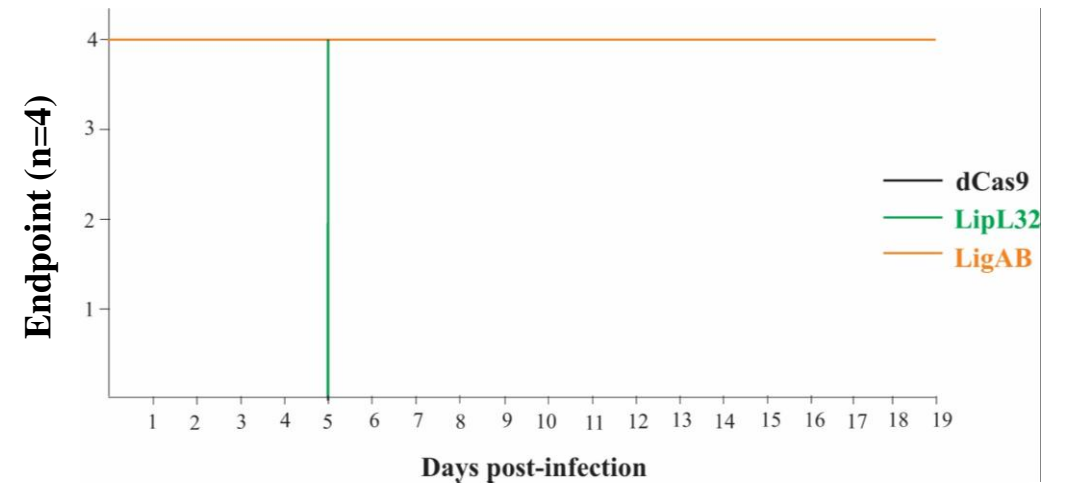
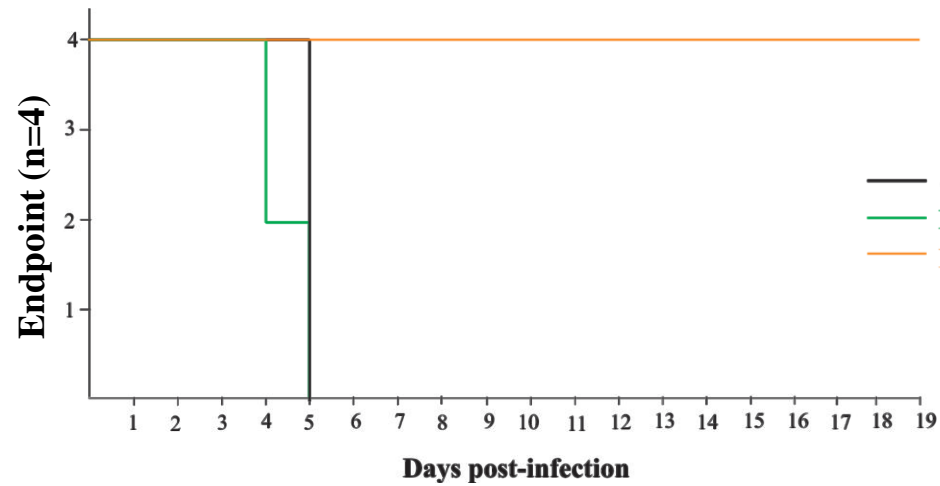
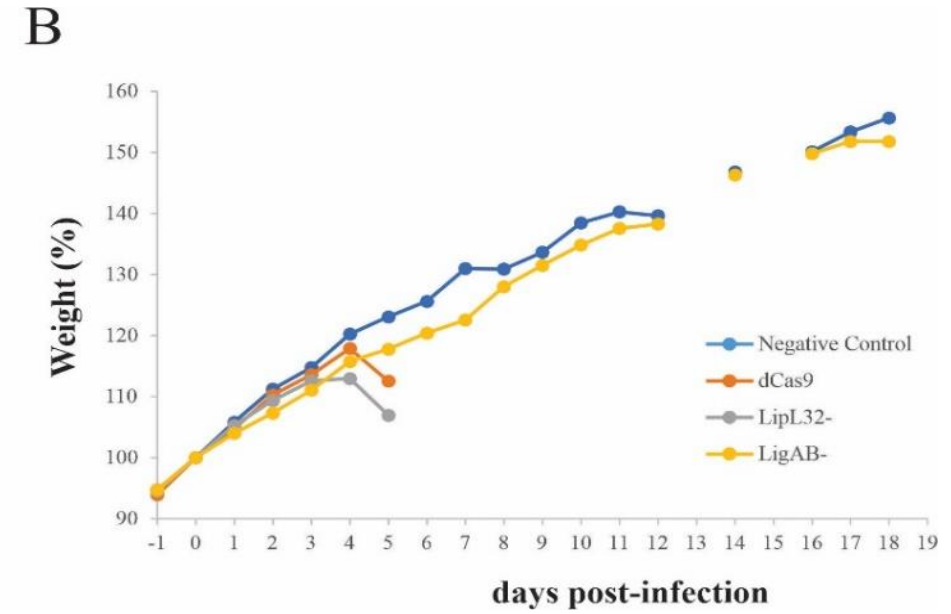
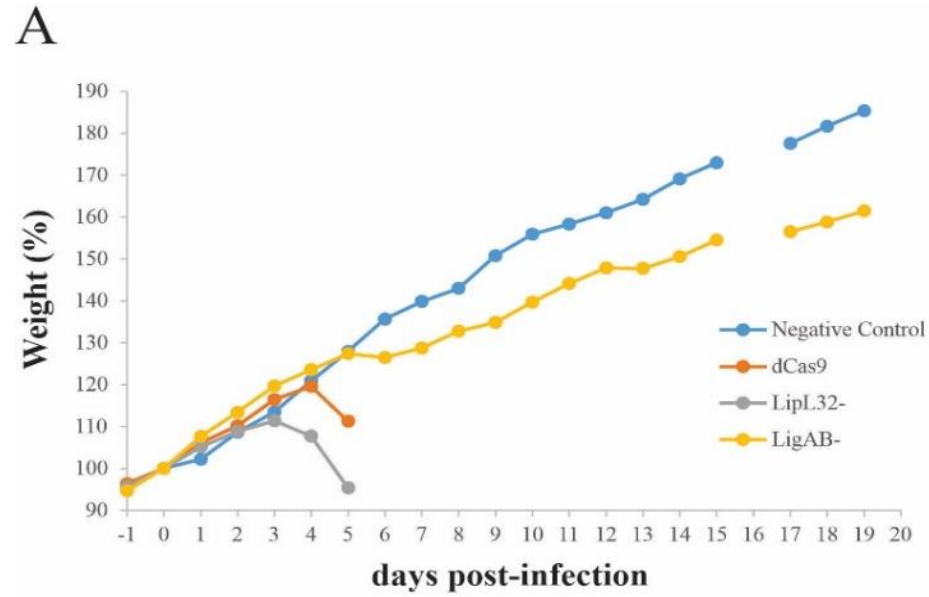

RESULTS

Detection of proteins in recovered leptospires

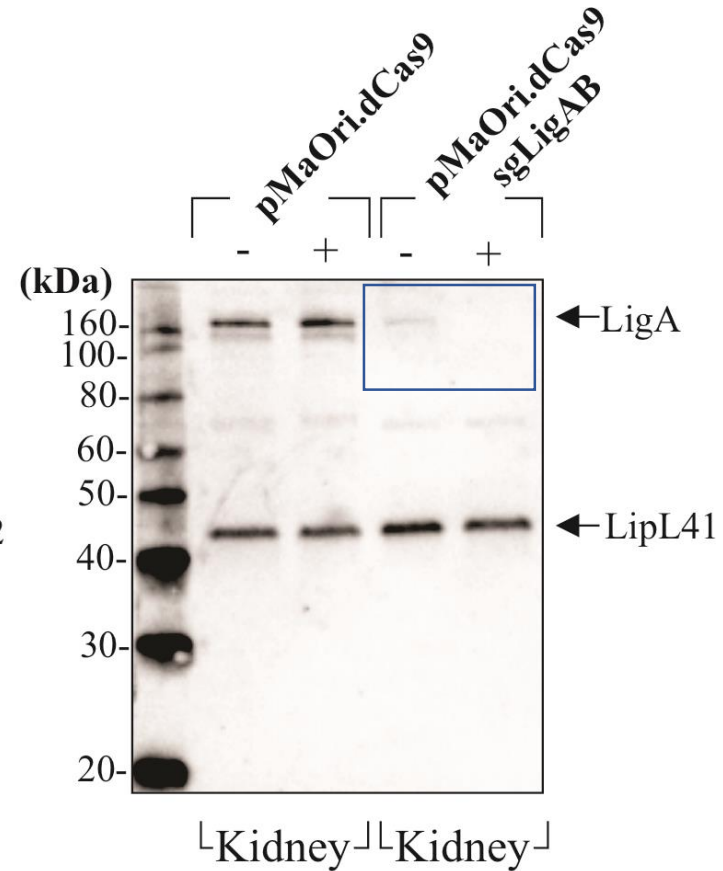
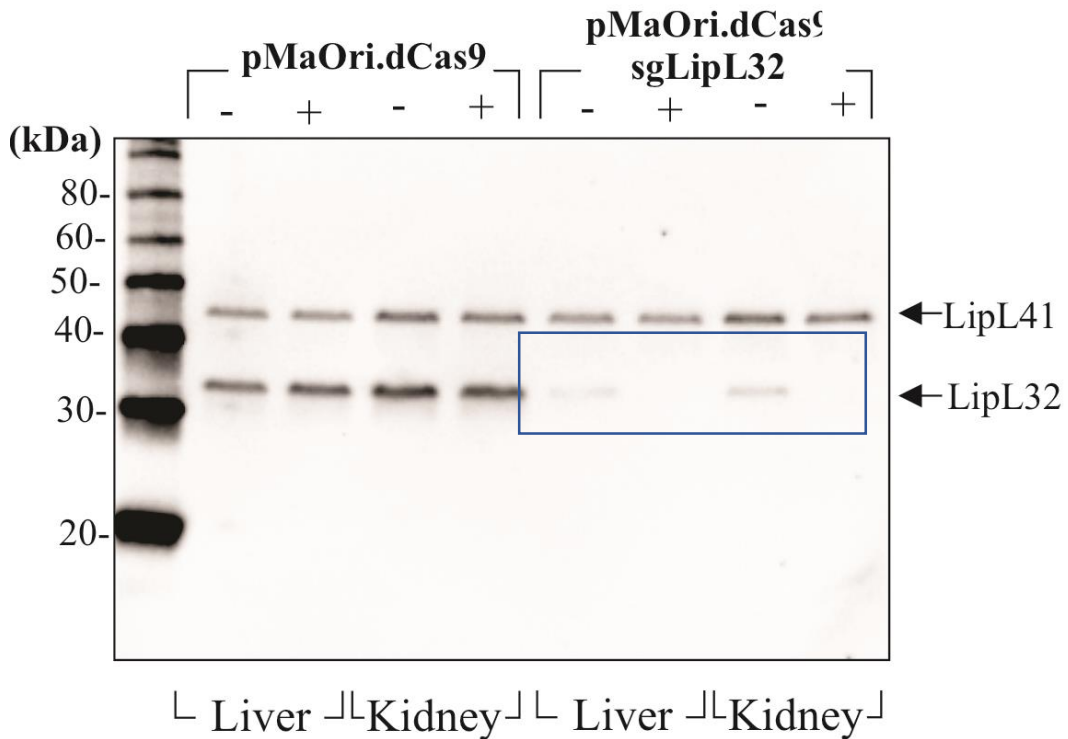

Compatible to the similar growth curve in both media with or without spectinomycin

LigAB double mutante caused chronic disease

RESULTS

Application of CRISPRi to other *Leptospira* species

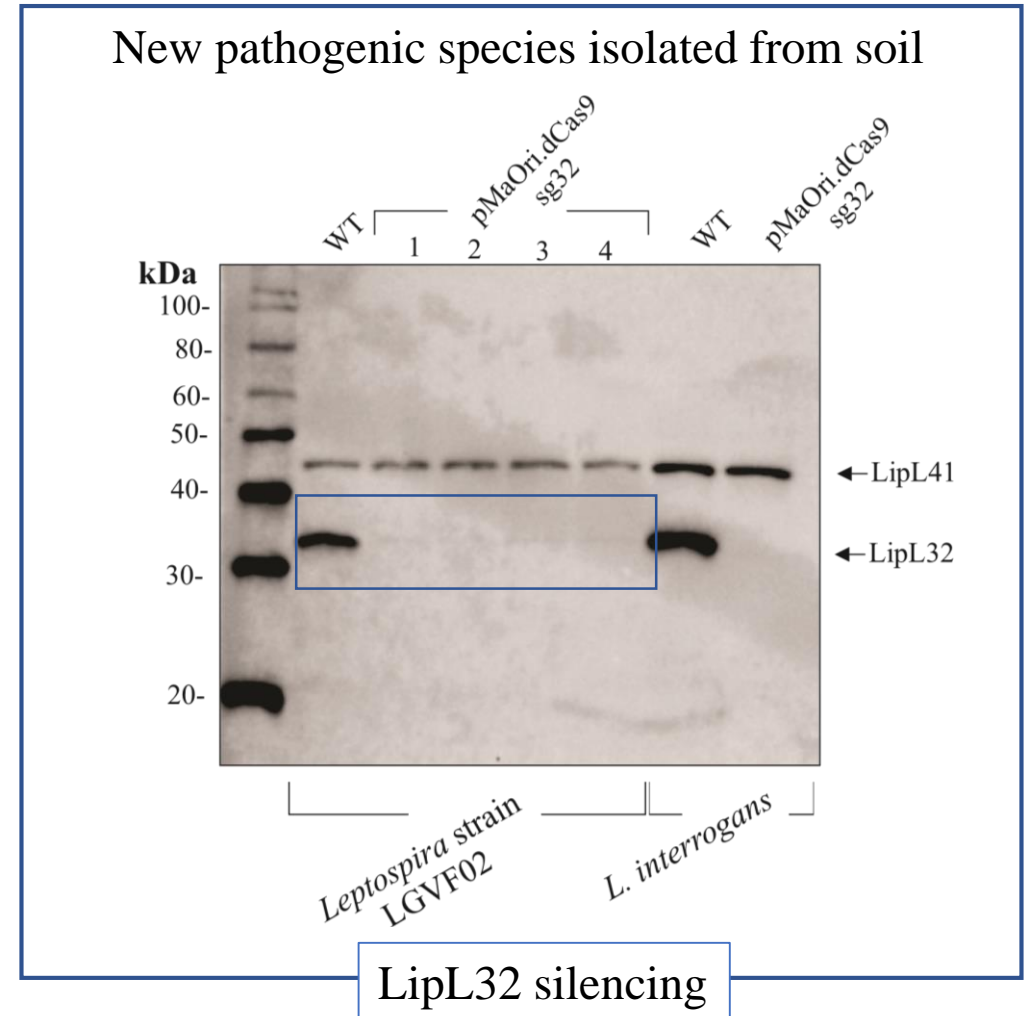
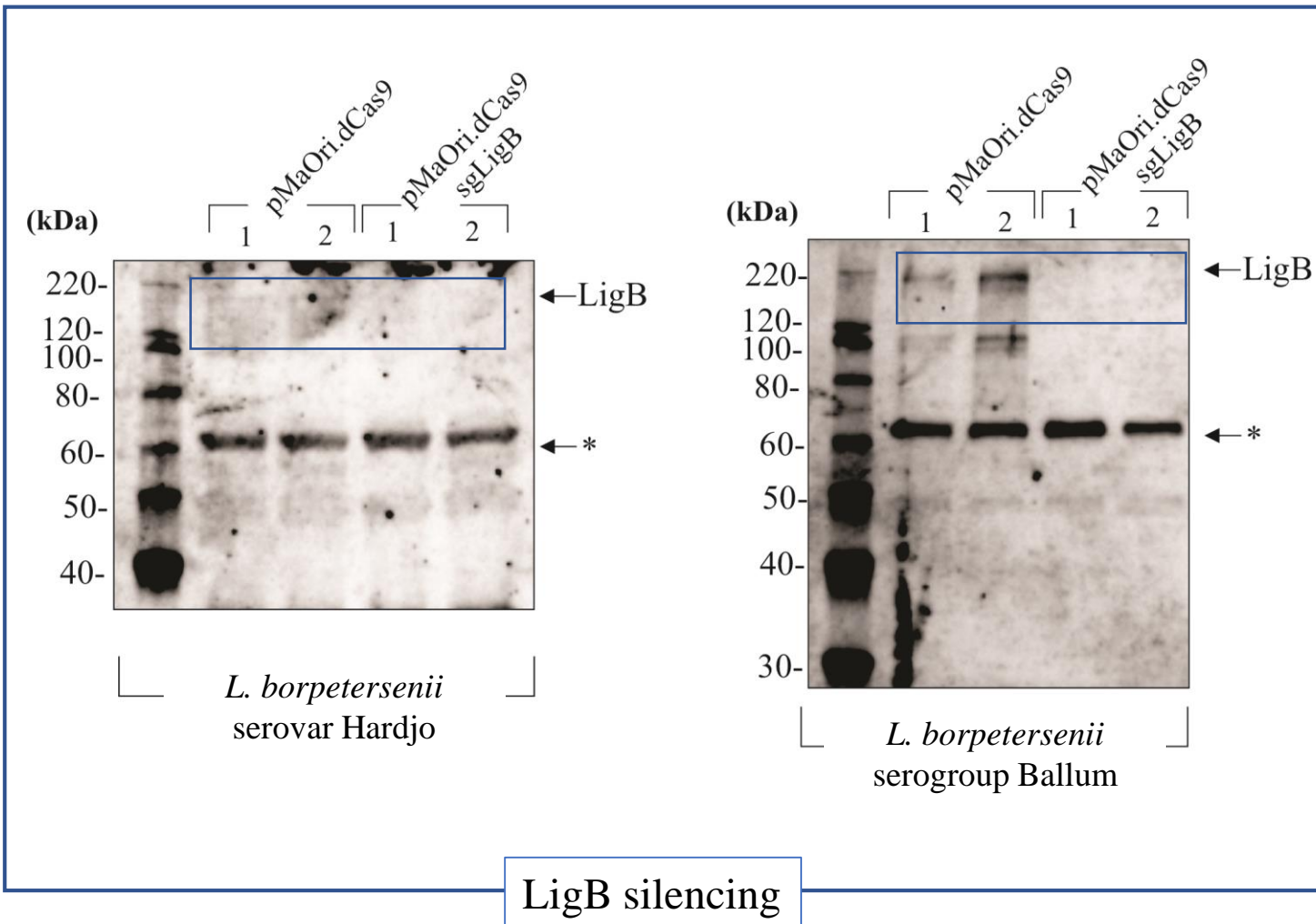

CONCLUSIONS

- ⇒ CRISPRi was successfully applied to distinct pathogenic *Leptospira*
- ⇒ Complete and stable gene silencing was observed, suitable for animal experiments
- ⇒ The loss of virulence of the double LigA/LigB mutant was confirmed, probably due to reduced serum resistance

scientific reports



OPEN

Genetic manipulation of pathogenic *Leptospira*: CRISPR interference (CRISPRi)-mediated gene silencing and rapid mutant recovery at 37 °C

L. G. V. Fernandes^{1,2,3}, R. L. Hornsby¹, A. L. T. O. Nascimento^{2,3} & J. E. Nally^{1,3}

ACKNOWLEDGMENTS



Dr. Jarlath Nally

Dr. David Alt

Richard L. Hornsby

Dr. Ellie Putz

Dr. Camila Hamond

Ami Frank

Judi Stasko



Dr. Ana Lucia Tabet Oller
do Nascimento



Microscopy Services

Judi Stasko

Adrienne Shircliff

Jennifer Lamoreux

Visual Services

Alex Grimes

Hannah Hill

**Vivarium small animal
care team**

THANK YOU FOR
YOUR ATTENTION!



- luis.fernandes@butantan.gov.br

